



## PRODUCT DESCRIPTION

### 3-PPS/M and 3-PPS/M-230 primary power supply

The 3-PPS/M(-230) primary power supply provides the required power and related supervision functions for the panel. The supply is comprised of two major components: the power supply monitor module, model 3-PSMON, which mounts on the rail chassis, and the heat sink assembly, model 3-PPS, which mounts on the rear of the rail chassis. The primary power supply provides filtered, regulated power to power all modules connected to the rail chassis as well as 24 Vdc for auxiliary applications. The primary power supply is rated at 24 Vdc @ 7.0A for all outputs. Two independent, power limited, supervised 24 Vdc, 3.5 A auxiliary power outputs are provided on the primary supply. 24 Vdc auxiliary output is available on plug-in terminals on the primary power supply module. AC power and battery connections are made to fixed terminals on the heat sink assembly, remote from the panel's power limited wiring.

The primary power supply supervises the standby batteries and provides a dual rate constant current battery charger featuring automatic temperature compensation. The charger is capable of charging batteries up to 65 Ah. A battery monitor circuit disconnects the batteries from the system when battery voltage drops below acceptable limits, which prevents memory problems and a total discharge of the batteries.

The power supply checks the ac input source and initiates the automatic transfer to batteries in the event of a brownout or loss of ac power. In the event of a failure of one or more booster power supplies, the primary power supply determines its ability, along with the surviving booster supplies, to supply the load. Should the load ever exceed the ability of the primary and surviving booster supplies to meet the demand, the standby batteries are automatically switched in.

The 3-PPS/M (-230) offers a comprehensive level of supervision. Dynamic battery load testing periodically disables the battery charger, loads the battery, then monitors the battery voltage over a predetermined time period. Battery failure is annunciated if the battery fails to maintain an acceptable voltage level. Load testing continues periodically, until the battery capacity is sufficient to meet the load test criteria.

The primary power supply monitor module provides the interface between the power supply and the panel making the required data and power connections to and from the rail chassis. The monitor module requires one connection on the rail chassis and is secured to the assembly using snap rivet fasteners. The module features a hinged front panel for mounting displays or a blank protective faceplate.

### 3-BPS/M, 3-BBC/M and 3-BPS/M-230, 3-BBC/M-230 Power Supply Booster

The 3-BPS/M (-230) and 3-BBC/M (-230) power supply booster modules are used to provide additional power over and above the primary power supply. Up to three additional 24 Vdc, 7.0A power boosters may be added in each enclosure, making a total of 28A available for both internal and external applications. The power supply booster is comprised of two major components: the booster monitor module which mounts on the rail chassis, and the heat sink assembly, which mounts on the rear of the rail chassis. Each booster provides filtered, regulated power to power all modules connected to the rail chassis as well as 24 Vdc for auxiliary applications. Each booster is rated at 24 Vdc @ 7.0 A for all outputs. Two independent, power limited, supervised 24 Vdc, 3.5 A auxiliary power outputs are provided on the booster. The 3-BBC/M (-230) can charge batteries. The 3-BPS/M (-230) shares a common standby battery with the 3-PPS/M (-230) or 3-BBC/M (-230). Each 3-BPS/M (-230) supervises its own connection to the battery, however, all battery charging and monitoring is done by the 3-PPS/M (-230) or 3-BBC/M (-230). The power supply boosters share the panel's 24 Vdc electrical load with the primary power supply. In the event of a failure of a booster power supply, a trouble is annunciated, and the panel load is distributed among the operational power sources. Should the load ever exceed the ability of the operable power sources to supply the power, as in the event of an alarm, the system will automatically transfer to standby batteries.

The power supply booster monitor module provides the interface between a power supply booster and the panel, making the required data and power connections to and from the rail chassis. The booster monitor module requires one connection on the rail chassis and is secured to the assembly using snap rivet fasteners. The module features a hinged front panel for mounting displays or a blank protective faceplate.



## SPECIFICATIONS

### 3-PPS/M (-230), 3-BPS/M (-230), and 3-BBC/M (-230)

Installation	Heat sink assembly mounts behind chassis rails Monitor module requires one module space
Power Input	120 Vac, -10%, +15%, 3.0 A, 50 - 60 Hz 230 Vac, -10%, +15%, 1.5 A, 50 - 60 Hz (-230 only)
Brownout Level	≤ 102 Vac ≤ 195 Vac (-230 only)
Outputs	
Total	24 Vdc @ 7.0 A, internal and auxiliary outputs
Internal DC	24 Vdc @ 7.0 A max.
Auxiliary DC	Two 24 Vdc @ 3.5 A max. ground fault and short supervised, power limited outputs
Termination	
AC Input	Terminals on heat sink assembly
Batteries	Terminals on heat sink assembly
Internal DC Output	LRM chassis rails via monitor module
Auxiliary DC Output	Removable plug-in terminal strips on monitor module
Operating Environment	
Temperature	32 °F to 120 °F (0 °C to 49 °C)
Rel. Humidity	93% RH non-condensing

### 3-PPS/M (-230) and 3-BBC/M (-230) only

Battery Charging	
Capacity	10 - 65 Amp-hours
Type	Temperature compensated dual rate
Supervision	
Low AC	
Low Battery (≤ 22.5 Vdc)	
High Battery	
Discharged Battery (≤ 18 Vdc)	
Ground Fault (≤ 10 k )	

### 3-BPS/M and 3-BPS/M-230 only

Supervision	
Low AC	
Low Battery (≤ 22.5 Vdc)	
Ground Fault (≤ 10 k )	

## 3-PPS/M (-230) and 3-BPS/M (-230)

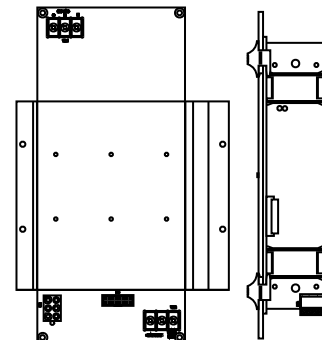

### INSTALLATION SHEET:

**3-PPS/M (3-PPS/M-230) Primary power supplies**  
**3-BPS/M (3-BPS/M-230) Booster power supplies**  
**3-BBC/M (3-BBC/M-230) Booster power supplies**

INSTALLATION SHEET P/N: 270495	FILE NAME: 270495.CDR
REVISION LEVEL: 3.0	APPROVED BY: D. Munn
DATE: 06APR01	CREATED BY: D. Miner

### EDWARDS SYSTEMS TECHNOLOGY, INC.

SARASOTA, FL: 941-739-4300 FAX 941-753-1806  
 CHESHIRE, CT: 203-699-3000 FAX 203-699-3075  
 OWEN SOUND, CANADA: 519-376-2430 FAX 519-376-7258  
 INTERNATIONAL, CANADA: 905-270-1711 FAX 905-270-9553



# INSTALLATION INSTRUCTIONS

## Step 1. Mounting the power supply assembly:

1. Position the power supply assembly behind the rails on the rail chassis assembly.
2. Attach the power supply assembly to the 4 threaded mounting studs.
3. Screw the bottom edge of the power supply assembly to the threaded stand-offs on the rail chassis assembly.
4. Secure the top edge of the power supply assembly to the rail chassis assembly using the stand-offs provided in the hardware kit.
5. Screw the power supply cover (not shown) to the stand-offs on the top edge of the power supply assembly.

### Notes:

1. The primary power supply must always be mounted in the left mounting position of the chassis containing the panel controller.
2. Monitor modules for power supplies mounted in the left mounting position may only be installed in rail slot position 3. Monitor modules for power supplies mounted in the right mounting position may be installed in rail slot positions 4, 5, or 6.

#6-32 threaded stand-off  
(2 places)

Right mounting area for installing  
second power supply

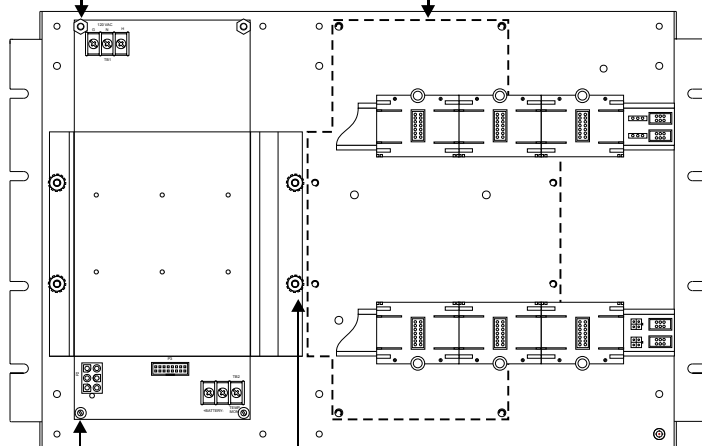

#6-32X3/8 pan head screw  
(2 places)

#8-32 lock nut  
(4 places)

**Caution:** This product contains components that are sensitive to static electricity. Failure to follow proper handling procedures to prevent damage from electro-static discharge may result in equipment damage.

## Step 2. Installing the power supply monitor module:

1. Connect the 6-wire cable harness to P6 on the power supply monitor. Push in until the connector clicks.
2. Connect the ribbon cable to J4 on the power supply monitor.
3. Align the power supply monitor to the slot 3 guide posts on the rail chassis assembly.
4. Route the 6-wire cable harness over and behind the bottom rail and connect to P2 on the primary power supply. Push in until the connector clicks.
5. Route the ribbon cable under the bottom rail and connect to P3 on the primary power supply.
6. Slide the module into the slot 3 rail connectors and lock into place using the snap rivet fasteners.

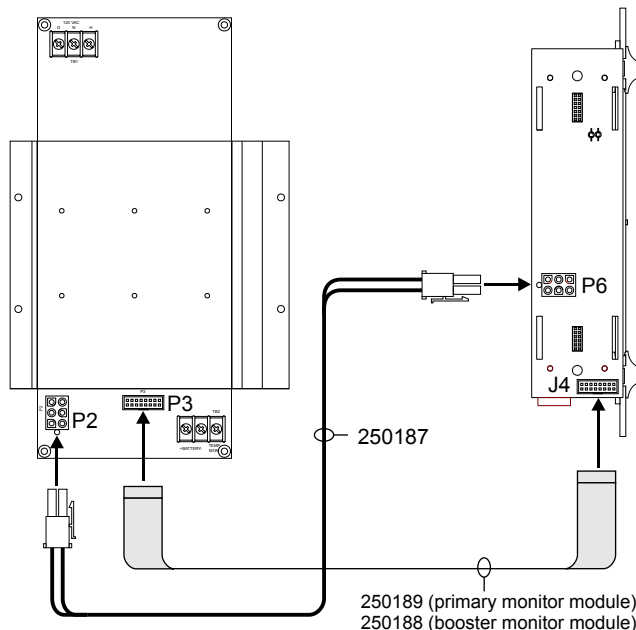

## Step 3. Wiring the power supply:

1. Ensure that the mains ac circuit is deenergized. Connect the mains ac conductors to TB1 on the power supply assembly. Refer to Figure-1 on page 3.
2. Connect the standby battery conductors to TB2 on the power supply assembly. Refer to Figure-2 on page 3.
3. If a remote battery cabinet is used, connect the temperature sensor conductor to TB2 on the primary power supply assembly. Refer to Figure-2 on page 3.
4. Connect the 24 Vdc auxiliary power riser conductors to TB1 on the power supply monitor module. Refer to Figure-3 on page 4.

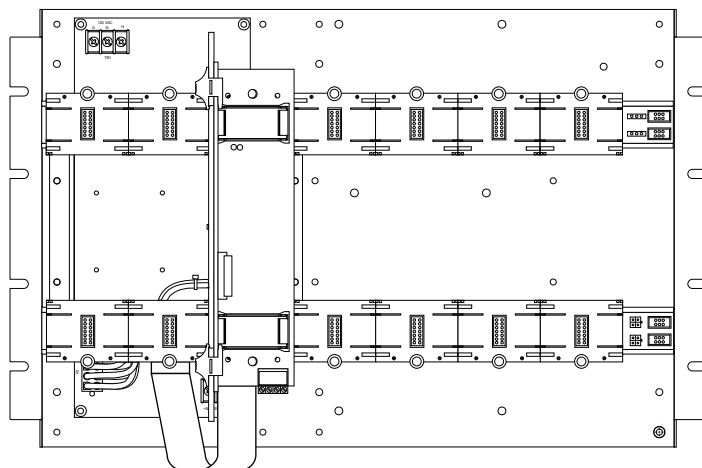



# FIELD WIRING CONNECTIONS

From dedicated mains ac power distribution (if primary power supply) or from previous power supply in same cabinet (if booster power supply)

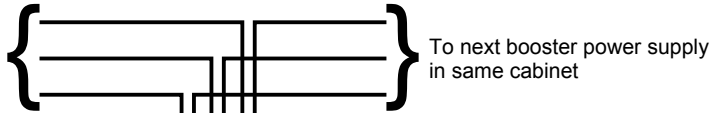

**WARNING:** High voltage levels capable of causing injury or death may be present. Precautionary measures must be taken to ensure that the mains ac circuit is deenergized and prevented from being switched on inadvertently.

**Notes:**

1. Install wiring in accordance with the National Electrical Code and all other local requirements.
2. Up to 4 primary or booster supplies may be connected to a single ac source circuit.

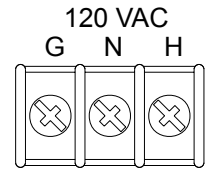
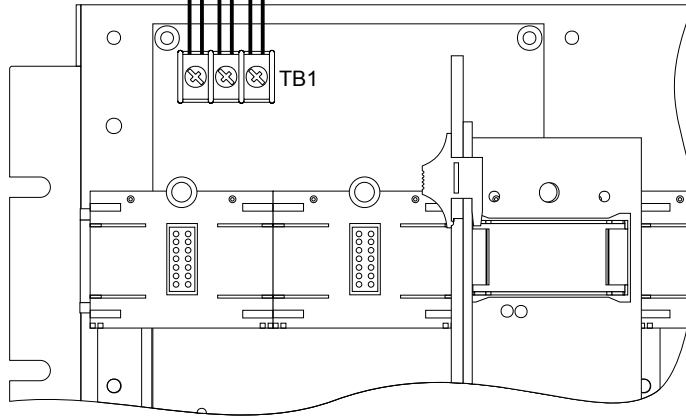

TB1

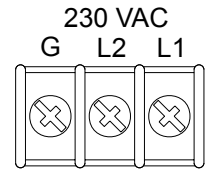

TB1

**Power supply assembly TB1 terminal designations**

**Figure-1: Mains ac wire connections**

**Cautions:**

1. Disconnecting the battery from the power supply while the cabinet is deenergized may damage the battery.
2. **All batteries that are connected to the same cabinet must be from the same manufacturer, must have the same amp-hour rating, and the same manufacturer date codes.**

**Notes:**

1. Each power supply shall have its own separate pair of conductors going to the battery.
2. The batteries must already be connected to the primary power supply when the cabinet is energized in order to activate the battery charging circuit.
3. The 3-PPS/M (-230) and 3-BBC/M (-230) are not to be used

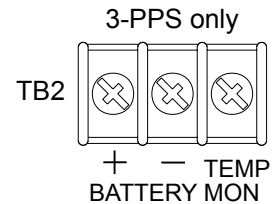
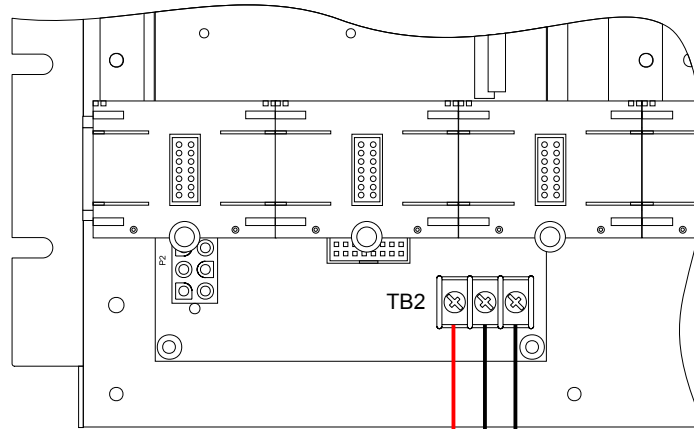

**Power supply assembly TB2 terminal designations**

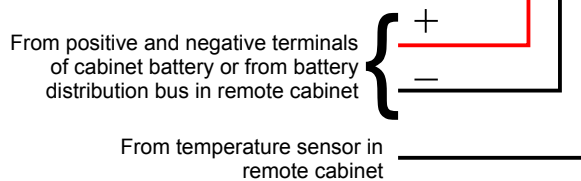

**Figure-2: Standby battery wire connections**



# FIELD WIRING CONNECTIONS

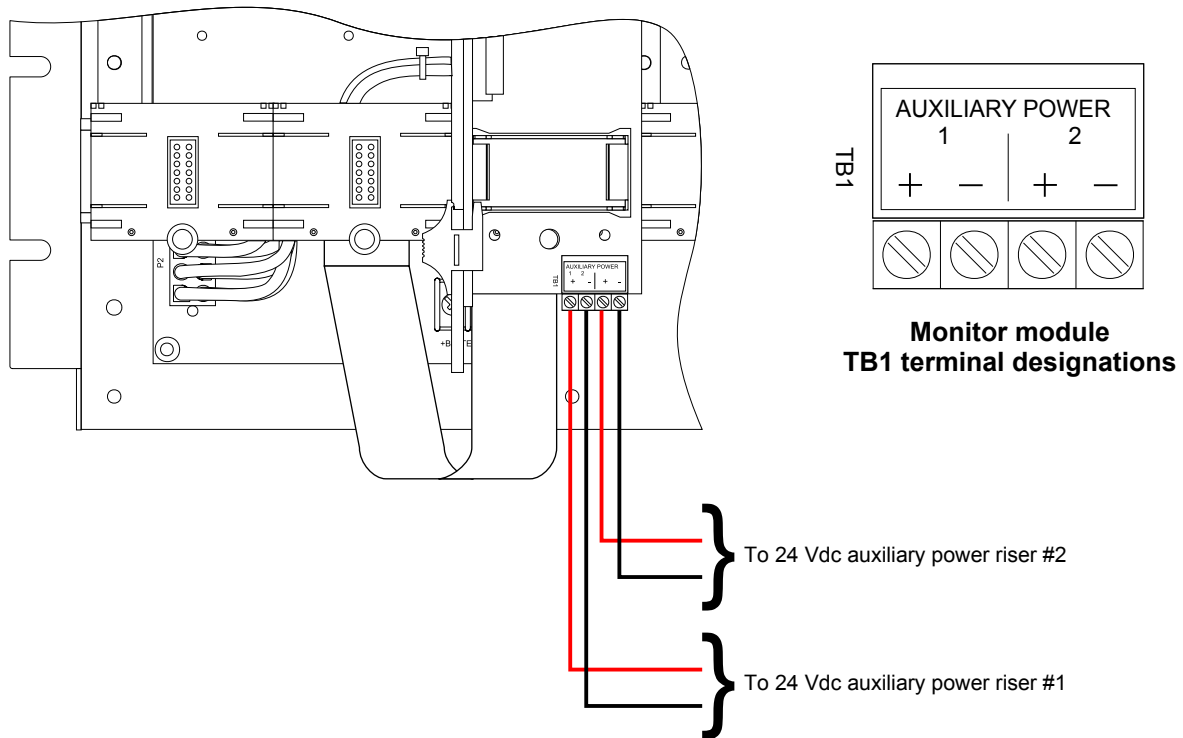

**Figure-3: 24 Vdc auxiliary power riser wire connections**